

Chapter 12: Ruling Ourselves

Is it possible for human beings to live together in a society in which all have equal rights, responsibilities and status? Does there exist a stable dynamic structure - a mathematical attractor - under which an egalitarian society could function? Or is hierarchy the only option? [Footnotes]

I have no tangible knowledge of any conscious existences that I may or may not have had prior to my being born as a human being roughly half a century ago. As awareness dawned, my observable universe was limited to my grandparent's home and its local shops. However, I soon realised that the world was a much bigger place than I had thought, and that it was home to a lot more people than I knew. I thought it went on forever, but soon learned that humankind all lived together within a thin biosphere around the surface of a near-spherical planet called Earth.

Planet Earth:

Mass: 5.98×10^{21} tonnes

Radius: 6,371 kilometres

Area: 510 million km²

Ocean: 361.3 million km²

Land: 148.8 million km²

Habitable Land: 130,693,000 km²

Population: $\cong 7,000,000,000$

Food Produced: 2,671 kcal/person/day

NASA photo (reprocessed)



As biological life-forms, we are not inherently self-existent. To survive, we need air, water, food, clothing, warmth and shelter. These the Earth freely provides. No amount of work could ever earn them. Our work is just a minor-but-necessary condition to receiving them. Transport us to a barren planet and no amount of work could earn us our daily bread. The Earth is the family estate of man. It is our inheritance by default. Within it we are free. No landlord charges us rent for living here. It is a rent-free planet. And no overseer forcibly constrains us to live and behave in any decreed way.

I would therefore have expected, as one of the Earth's 7 billion or so inhabitants, to have received my fair share of it on which to live and with which to transform my labour into my needs of life. I would have expected to have received this as a free and unencumbered birthright. But sadly, like the overwhelming majority of mankind, I never received any such thing. So in order to survive, I am forced to sell my labour to those few who did. Yet they seem to have no obligation to buy my labour, and they will do so only if, and for as long as, they perceive themselves to have need of it.

A Stolen Birthright

Ownership, possession and control of the Earth seems to be divided among a certain few exigent individuals. They, it would seem, have commandeered (or, more correctly, *stolen*) all its land and that which lies beneath it and grows upon it. These few have appointed to themselves the unmerited right to decide how our planet's resources are used and by whom. Most of us have direct economic control over no part of our native planet.

Yet everybody needs food, clothing and shelter. Anybody who does not possess free use of sufficient natural means of converting his labour directly into these things is necessarily beholden to somebody

who does. The *one who possesses* is the master. The *one who does not* is his slave. The only thing the slave has to offer in return for his needs of life is his labour. The slave must labour for the master in order to receive his needs of life. He must serve a master to survive.

The slave needs the master. The master does not need the slave. Consequently, any agreement or contract between them is on terms dictated solely by the master. The slave may simply accept or reject the terms. He may not change them. The slave has a simple choice. He may choose to work for the master on the master's terms, or he may choose to die from starvation and exposure. Of course, he could take his chances and become a criminal, living by stealing back from a master a small part of the produce of the natural birthright that the master has already stolen from him.

A slave does not have equal rights, responsibilities and status to a master. So, by definition, masters and slaves cannot be elements of an egalitarian society. The fundamental pre-requisite for an egalitarian society must therefore be that each must possess the inalienable right to use sufficient terrestrial resources to be able to directly turn his own labour into his own needs of life. Only in this way can every member of society potentially relate with every other from the same position of strength. To be able to live equitably, we each need an inalienable equal economic stake in the planetary biosphere within which we were all born.

Divided, Subjugated and Ruled

Why, unlike that favoured few, did I not inherit my fair share of my planet? It is because my rightful inheritance was stolen from me before I was born by the forebears of that favoured few. But how could they manage to steal not only my inheritance but all the inheritances of the vast majority of mankind? They did it by stealthily [dividing us against ourselves](#).



They did it by attenuating and trivialising the ways in which human beings can relate with each other and imposing a divisive economic disparity between them. Through State law, religious fear and cultural conditioning they suppressed and short-circuited the most powerful link between human beings, namely, [inter-gender friendship](#). Through the division of labour they factionalised the working class, pacifying it by focusing its mass mind on trivia. They ranked the educated middle class, infecting it with the ethos of greed to dissipate its energy in futile competition. They have even severed the links of community, family and marriage through the geographic polarisation of skills. All have thus become as dust, scattered as lonely isolated souls wherever the corporate winds will blow them.



Why are we so helpless? Why do we, who are of great number, accept our dispossession and enslavement? Why do we let ourselves be deceived by the elite, their politicians, their media and education system? What possesses us to toil each day to sustain and extend an economy that is clearly not working in our best interests? Why do we tolerate a society in which the elite - through the State - can exert overwhelming force to crush the individual? Why do some of us prostitute ourselves to act as physical enforcers of the State's will against our fellows? Why do we side with evil power against the righteous individual?



It is because the vast majority of us are passive, apathetic, ignorant cowards. We are too acceptive of the way things are. We are willingly enslaved by delusion. It's the lazy way out. It avoids confrontation with an evil that is stronger than we are. We cringingly shy away from such a burden of responsibility. Change is simply too much trouble. It is so much easier to remain drugged in a nirvana of football and soap operas, pop songs, beer and celebrity gossip. So, our state of dispossession and enslavement can only be our own stupid fault. So we have no justifiable cause to gripe about the booms, the busts, the widening disparity of wealth and increasing job uncertainty.

Clearly it is all our own stupid fault. We are donkeys. We are the turkeys that voted for Christmas. But just suppose that on day we were to decide we wanted to change it. What would we have to do? How could we proceed? Ensnared in its illusion of freedom and well-being, the vast majority is never going to rise up *en masse* in armed revolution to overthrow the status quo. Only a small few are ever likely to be moved to do anything about the present state of things. And most of them are not likely to be connected with each other. Each will probably be a single soul acting unilaterally. So what can you, as an isolated individual, possibly do to make a difference?

We Must Think and Link

Invade, conquer and rule the territory of your mind. Free your thoughts from the prison of implanted ideas. It is only a virtual prison. You can escape from it any time you wish, merely by taking the thought to do so. Change your mental paradigm. Stop blindly swallowing what the established education system and public media feed you. They mould your thoughts to conform to their masters' wishes. Don't be addicted to mind-numbing trivia like football, soap operas, competition and petty politics. They are subtly engineered to dissipate your mental energy, leaving you without time for the deeper considerations that could invoke ideas contrary to the selfish interests of those in control.



Think independently about the world. Ladle upon it some well deserved criticism. Delve beneath the cultural veneer into your natural conscience. Take on the moral values it contains. Test what you read and hear. Subject it to the scrutiny of conscious reason. Observe. You don't need a degree to do this. In fact, you're probably better off without one, thereby being free of prescribed ideas. Upon this foundation, construct a framework for what you honestly think would be a just and fair society. Create a personal project whose practical details can form an inspirational model that generations to come can adapt to their own preferences and circumstances. But keep the detail flexible. Don't become fanatical.

Then try to reach others of like mind. I have tried to do this by creating this vast web site, the whole purpose of which is simply to provoke people into thinking for themselves about their lot within the social orders of this present world. Sadly, due to changes in search engine policy, few people nowadays can find it directly. I tried to circumvent the problem by using social networks. But these were never meant to link like-minded people and are consequently useless for so doing. They are simply to harvest information about people so that commerce can precision-target its advertising. I linked strategic articles from this web site into established Webrings. I mounted them as *freesites* on

Freenet. I made them into PDF files uploadable via the Gnutella and eDonkey networks. Happily, this is now gradually bearing fruit.



Nevertheless, it is forever being made more difficult for members of minorities to link with like-minded peers. Remember that the powers-that-be do not want radically thinking people to get together to form grass-roots social networks. It is definitely not in their interest to allow this. Consequently, I fear, it will take many generations for people to form themselves into a grass-roots network with the critical mass necessary to be able to change the world. Yet, I believe that, in the

long term, it is inevitable. Nothing can stop it. Even the rulers of this world cannot suppress human progress forever.

A network will eventually start to form. Its slender mycelia of [friendship](#) will stretch out ever further to link sincere like-minded thinking people all over the world. Upon its foundation will emerge a new web of knowledge that will become the basis for an uncloistered system of education to which all who wish may have free and unencumbered access.

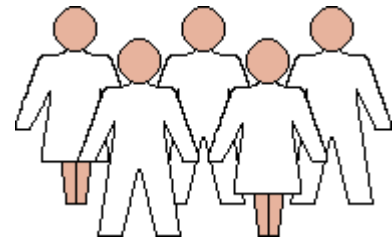

This will give us knowledge and connectedness but it will not grant us power. We will still be economically dependent on those who possess and control the land and natural resources of this planet. Thus we are still under the power of the elite. But being knowledgeable and connected we can act together in a coordinated way without the need for a hierarchy of command. But how should we act? What should we do?

We should prepare ourselves for the time when elitism will inevitably destroy itself. The financial and corporate hierarchies of today are exploiting the people of the world ruthlessly and without the slightest vestige of mercy. Disparity will accelerate. Soon the poor will not be able to survive. They will have nothing to lose. The world will explode into terrorism and overt armed conflict. Markets will become increasingly unstable until they fibrillate to the point of self-destruction. Inflation will render all forms of money worthless. The hierarchies will implode and evaporate. This will leave a dangerous power vacuum.

By this time, we must have laboured diligently enough to ensure that our network had grown to the critical mass necessary for our voice to be heard. We must convince the people of this planet that the Earth is their rightful inheritance. We must be able to show them how to use it fairly.

We Must Reclaim What is Ours

Now they can take power. They can now take possession of their lost inheritance. They can now force the old elite to give back to each his rightful [share in the land and resources of the planet](#) on which he was born. And this *rightful share* must be protected by an [immutable manifesto](#), which must be binding on all humanity.



This is your
Lost
Inheritance

Every human being alive today has the inalienable right to just over 2 hectares of habitable land on which to live and with which to turn his labour into his needs and luxuries of life.



Land, Wealth and Capital

But why land? The power that drives all the economies of the world today is capital. It is the essence of wealth and power. Why then do I see land as the future basis for personal wealth and security? Wealth is the measure of human needs and desires. There is only one fundamental mechanism that produces wealth. That is the application of human labour to land. Work of itself cannot produce our needs of life. Move mankind to a [barren planet](#) and neither his millennia of accumulated knowledge nor any amount of desperate labour will earn him salvation from almost instant starvation. It is therefore dangerous and immoral for any elite minority to sever or restrict any individual's direct use to his fair share of the natural environment to turn his labour into his needs of life.



Capital is a well-engineered illusion. Real wealth - the needs and luxuries of human life - is generated only by applying labour to land. The greatest costs over the lifetime of most people in the world today are those of a tiny piece of land with a house upon it and the food, clothing and fuel they consume - all of which come from land. A substantial proportion of the costs of any enterprise is that for the office or factory space within which it conducts its business and the materials and energy it uses - the space and substances of land.

In a future world, each must have a stake in the planet on which he was born. This need not be a specific piece of land at a particular permanent location. It needs to be a more flexible concept. This will demand a radical re-think about our notions of [land, wealth and capital](#) and our [perception of ownership](#). But merely returning to every human being his own fair share of the planet is not enough. It will be necessary also to establish a new and revolutionary [socio-economic system](#) that is specially designed to facilitate equitable dealings between the citizens of this future world.

Yet even this is not enough. Each now has a newly-defined ownership of adequate terrestrial resources with which to turn his labour into his needs of life. The social, transport, communications, education and welfare infrastructures are there to enable him to exchange goods, services,

knowledge, culture and care. But all this amounts to nothing without a further missing ingredient. He must be equipped and motivated to be able to relate with his fellow inhabitants of Planet Earth.

We are now in a world of independent friends, each of whom has his own separate means of turning his labour directly into his needs of life. Each has access to a fair and free market through which he can exchange what his specialized skills can produce for things he would like that are produced by the different specialized skills of others. He lives in pleasant surroundings as a member of a distributed population. He has access to a system of universal information and education that lends itself to his way of life.

But this is not a society. It is merely the euphoric aftermath of revolution. The old elite cliques and allegiances still exist under the surface. What is to stop the old hierarchies from regrouping and seizing power again? What defence do we have against re-enslavement under a new implementation of the old totalitarian principle? Conventional friendship is not enough. Its tenuous links can be broken, as they always were in the past. So how must we relate with each other? What structure of connectivity must we adopt in order to link this world of individuals into an egalitarian society?

A Global Network Society

All civil and economic connective structures of today's society are hierarchies. You are governed by a civil hierarchy. You are judged through a judicial hierarchy. You work under a corporate hierarchy. To live and survive in today's world, you have to serve somebody. You are, however indirectly, a slave. If we challenge the hierarchy as the natural structure for society, we are told to look to nature, the way everything is ordered and sustained in hierarchical structures. But nature is not hierarchical. Societies of animals and insects have much more the form of a [network](#).

And this is the obvious non-hierarchical form in which human beings could best connect. Each could form a strong trusting egalitarian relationship with a small number of others. Empirical evidence suggests that the ideal number of others with whom one can form such intense relationships is 6, although it will naturally vary from person to person. This regime can be physically imagined as a person in the middle surrounded by 6 trusted friends.

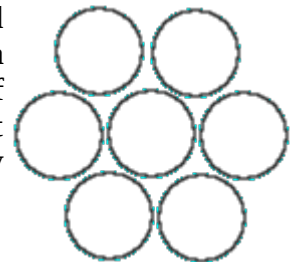

Each member of one's inclusive group of 7 is linked, through trusted egalitarian relationships, to 5 other *different* individuals. Many of these interpersonal connections would, naturally, be geographically local. Yet if only a few people were to have an extra far-reaching link, any two people in the world would become connected through a relatively small number of trusting relationships. All humanity could thereby become connected through an egalitarian small-world network.

Notwithstanding, there is an *as yet missing* ingredient needed for such an egalitarian society to work. To break free of the old order, we must reconnect at the grass-roots level. But not in a partisan manner through religions, professional or academic societies, commercial associations, secretive lodges, clubs, political movements or trades unions. Our interconnections must be all-inclusive and invincible. We must connect universally through bonds that are too broad and strong to be broken by the financial, commercial, political or religious forces of selfish gain.

The big question now is: what kind of inter-personal bonds must these be? What kind of egalitarian relationship is inherently stable and unbreakable? What kind of relationship could withstand the destructive pressures that caused human society to degenerate into its old hierarchical structure in the first place?

People Must Relate Differently

Today's hierarchical society expects and encourages the individual to act selfishly. He is fully expected and encouraged to exploit the Earth and its inhabitants for maximum short-term self-gain, irrespective of the collateral damage or ruination it may cause to others. Left unbridled, such a society of individualists would rapidly destroy itself. In an attempt to make such a society sustainable, government constrains its subjects to pursue their selfish ends within the rule of law. If, in the pursuit of his selfish ends, an individual strays outside the limits of the law, he is punished. He is thus confined within a cage or prison of legislation. The force that keeps him in this prison is the brute physical force of the State.

In today's hierarchical society, law is formulated by the elite minority. Because they, as individuals, are primarily motivated by self-gain, they fashion the law to favour their ends. They design it to facilitate the containment and exploitation, by themselves, of the masses beneath them. The physical force of the State is consequently oriented to subjugate the majority, and, by default, to oppress and cause misery to a remnant minority at the very bottom. This results in material self-gain for the elite. It supplies to the majority the means for continued existence. It leaves a poor minority in misery.

The exploitive nature of the relationships the elite have with each other thus propagates downwards through the social hierarchies to infect the subservient majority. In such a society, the relationship between any two "citizens" is effectively nothing more than a business relationship. It is based on the notion of "how do I get the most out of him while giving him as little as possible in return". This is the main - if not the only - motive for members of this kind of society to interact. It is a society of customers, clients, workers and bosses, employers and unions. Their relationships are exploitive, adversarial and confrontational.

Such relationships are, in a purely technical sense, repulsive. That is, they are human interactions that occur when people are unwillingly *pushed* together by an external force. That external force is the economic need to survive. People relate in this exploitive adversarial confrontational way because the hierarchical socio-economic structure under which they live makes this the only way they can survive. Give each the means to directly turn his labour into his needs of life and the hierarchies will evaporate. The compressive force that makes people relate in this way will disappear. People will no longer have a compulsive motive to interact. They will no longer relate.

But this would not be a society. Mutually isolated, the vast majority would soon find themselves once again prey to an exigent few who would quickly beguile them out of their land. For their own protection, people need to be linked. However, without the external force of economic necessity to *push* them together, what else could possibly motivate them to interact and form relationships? The answer is that the force must come from within the people themselves. And it must be a force of attraction, not repulsion. It must *pull* people together.

Now, if people are pulled together by a powerful force of attraction that emanates from within themselves, what will be the anatomy of the relationship that ensues? Because this involves each pair of individuals concerned being mutually attracted to each other, they come together of free will, not from economic necessity. So their ensuing relationship will not be exploitive, adversarial or confrontational. The only possible kind of social relationship that can ensue in this situation is [friendship](#).

A Special Kind of Friendship

By far the strongest social force of attraction between human beings is the *sexual* force of attraction that exists naturally between individuals of opposite gender. Today, the effectiveness of this force is

severely attenuated - if not almost wholly suppressed - by the present socio-economic structure. However, with the old oppressive hierarchies of religious fear, political subjugation and corporate greed eradicated from this planet, *sexual attraction* is the most dominant force that could drive humanity to spontaneously self-connect into a fair and stable society.

Notwithstanding, the force of sexual attraction alone is not enough. To create a fair and stable society, this powerful force must not be allowed to run riot. It must be harnessed and controlled. It must be applied with skill to create and sustain an extremely powerful kind of friendship: an intimate, balanced and permanent inter-gender friendship. This must become the backbone of society. A network linked by inter-gender friendships can provide the socio-economic superstructure under which people will be free to form multiple strong stable unions.

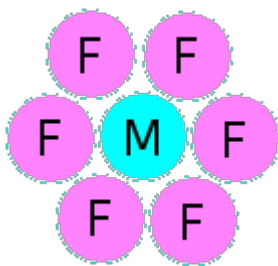

A social group of men only or women only is inherently less stable and cohesive than a group comprising an equal number of each. A social network, in which the major connections are male-female, is bound to be inherently more stable and cohesive than one in which the major connections are between individuals of the same gender. Only a social network of male-female links can possibly be robust enough to resist the degeneration of society once again into exploitive hierarchies.

The elements of such a social network would be as illustrated by the adjacent diagrams. Above is shown the one form in which each man (central blue circle) is connected through trusted egalitarian friendships to 6 female friends (peripheral pink circles). On the right is shown the other form in which each woman (central pink circle) is connected through trusted egalitarian friendships to 6 male friends (peripheral blue circles).

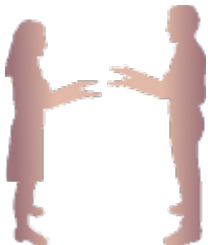
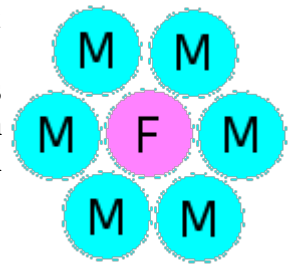

A global network of inter-gender friendship would free the mind from the prisons of religious and political doctrine, giving all the complete freedom to discuss anything openly with anybody. Gone would be the societal undertones that impose that ubiquitous awkwardness upon the notion of a separately married man and woman being intimate friends. The better half of our world of potential friends would thereby no longer be denied to us.

Of course, men profit from free and uninhibited discussion with men. Women profit from free and uninhibited discussion with women. But this does not allow male and female views to combine. The human mind cannot be liberated to its full potential unless or until man can universally engage in free and uninhibited discussion with woman. Only the stereoscopic picture created by combining male and female views can empower the human mind to see through the fallacies of this present world to catch a clear vision of the greater way things could be.

The force of inter-gender attraction is very strong. Notwithstanding, inter-gender friendship is not of itself sufficient to form a robust society. It needs to be defined, formalised and organised within the context of a new social order. It is vital that people be schooled from birth in how to develop it and use it to good effect. Only then can it become the universal connective force that will drive humanity to spontaneously self-connect into a robust global network of inter-gender friendships, within which the ancient oppressive hierarchies could never again re-establish themselves.

Optimum Network Topology

From the psychological and interactive standpoint, the ideal number of opposite-gender friends with which an individual should connect is 6. This ensures maximum cohesion between friends. From the standpoint of network topology, on the other hand, the ideal geometry is hexagonal. This results in each individual connecting directly with only 3 opposite-gender friends.

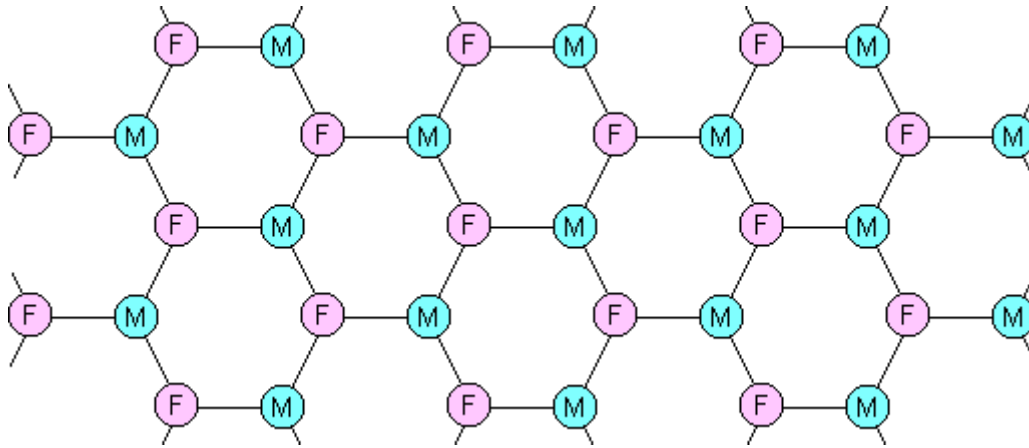

If each person had 2 connections, society would be no more than a vulnerable single line. The linkage between any two generic individuals would necessarily be very remote. One connection would result in the paired isolation of conventional monogamy. A square topology would result in every pair of men sharing a pair of women and vice versa, which would be too incestuous. Any number of connections above 4 would be even worse in this respect. The hexagonal or bee-hive topography is therefore the optimum form for a network society.

When everybody has 3 intimate relationships to maintain, some degree of asymmetry will develop in the relative strengths and proportioning of time between the three. They are unlikely to be equal in all respects. Consequently, the 3 relationships will likely develop into one primary marriage, with the other two - although equally vital to their participants' lives - taking on a somewhat secondary status. The hexagonal network topology accommodates this situation perfectly.

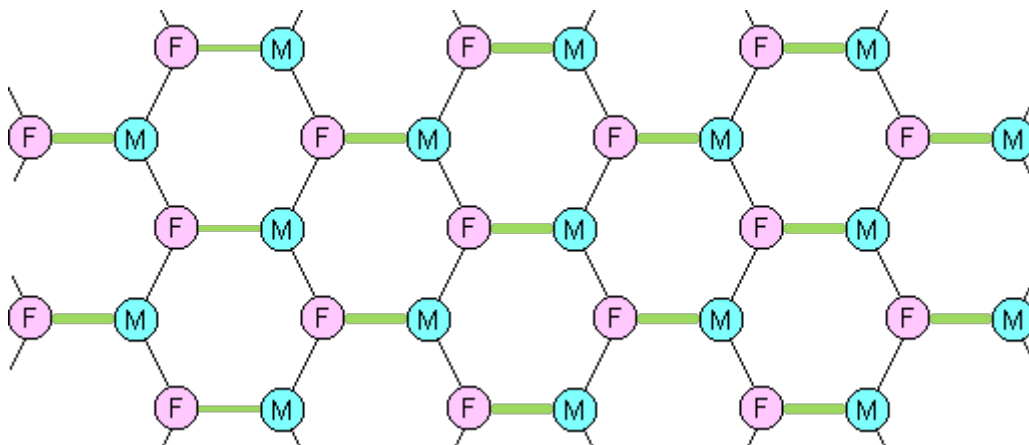

The broader horizontal green links in the above diagram illustrate primary-level marriage links, while the normal thin sloping black links indicate secondary-level marriages. The same two-level bonding can work equally well in a slightly different way as shown below.

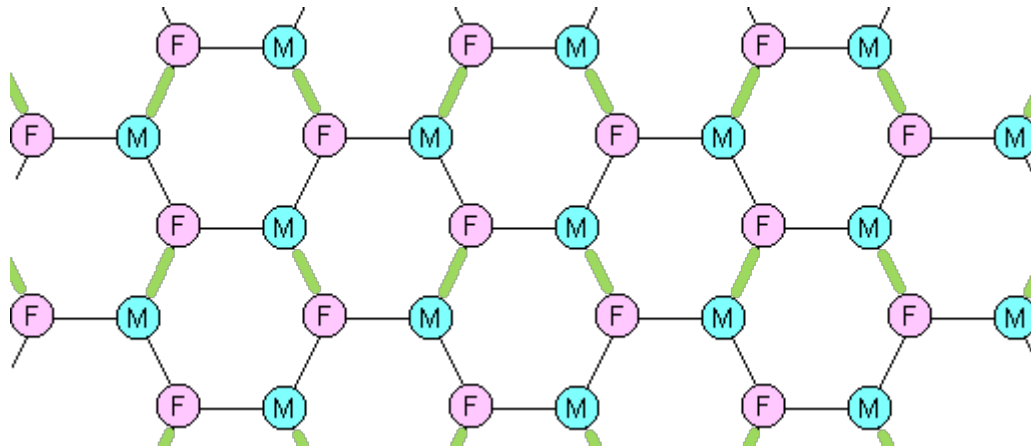

But how can the apparent conflict between the psychological and geometrical ideals of 6 and 3 connections be reconciled. The answer is by each person having *up to* 3 extra long-reach links, thus making *up to* 6 in total. The hexagonal geometry only shows what could be termed "local" links. Each person has 3 "local" links. Each person also has from 1 to 3 "remote" or long-reach links to opposite-gender friends spanning across multiple hexagons. The result is what is termed a "small-world" network, because it makes a big world seem small. The result is that any two people in the world are separated by very few inter-personal links.

From the point of view of practicality, local relationships must necessarily be more intense than long-distance relationships. Local relationships are, in effect, a primary and two secondary marriages. They are sustained by day-to-day and week-to-week interactions, which sustain families and domestic economies. Long-distance relationships involve much less frequent interactions, but are nonetheless equally intimate. They are the global conduits of culture and trade.

Socio-Economic Structure

In a society of individuals, each with his own landshare, connected through a hexagonal network of alternating genders, how could a practical socio-economy be implemented? Two possible options immediately spring to mind.

The first option is where each individual occupies his own physical landshare and is married to the three individuals with adjoining landshares, in the configuration shown on the right. A third of the landshare, of each member of a binary relationship, is used jointly as living space and for their joint economic endeavour. In this configuration, each individual has his own *ninho* (my term for a combined or integrated home-cum-work facility).

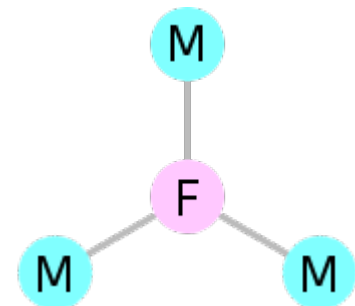

Each person's *ninho* is located somewhere in the middle of his landshare. Each *ninho* contains three sets of accommodation and work facilities, one for each of its occupant's three relationships. Of course, these three sets of living/work spaces do not have to be identical internally. Each specifically evolves to support the particular character of each relationship and shared interests of its participants. One of many concept designs for an individual's *ninho* within his landshare is shown below.

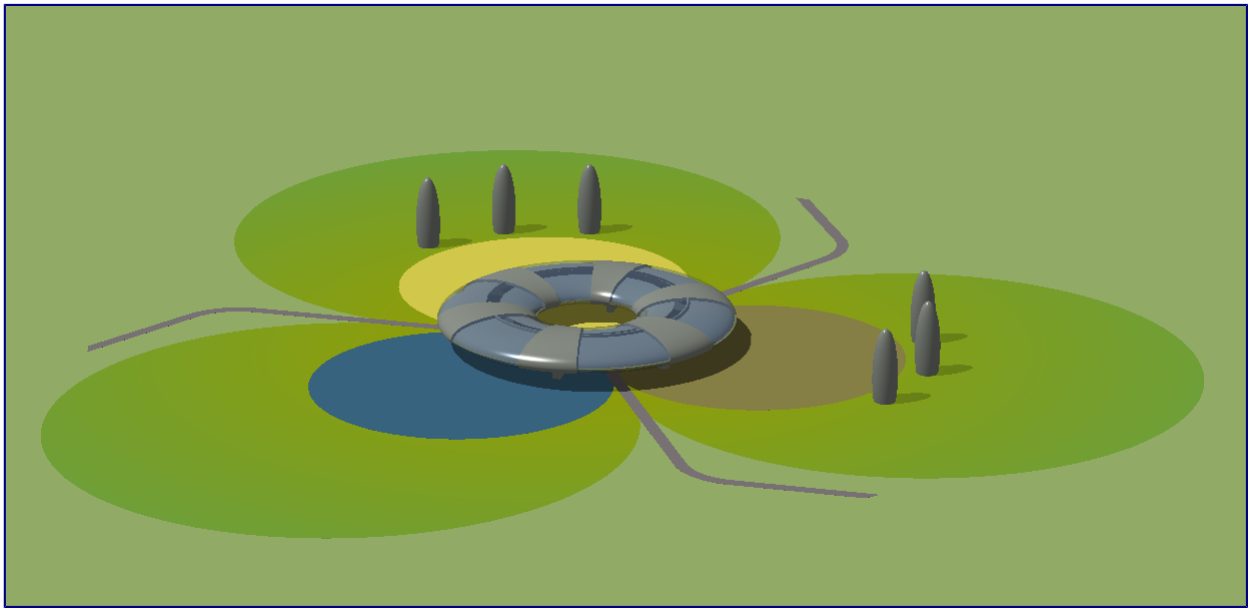

This design tessellates to form the simple hexagonal network structure. The landshare's area is divided into three circular lobes, each one being a third of the complete landshare area. Two of the thirds each contain a smaller circle where crops can be grown. The other third contains a shallow lake, which can be used as a water reservoir and for cooling.



Suppose one's physical landshare is not located adjacent to the three intimate partners of one's choosing. The solution is a landshare swap to relocate as close as possible to one's chosen partners. An individual's ninho is something personal and evolves its design and facilities along with its owner throughout his life. One's ninho should therefore be vehicular, with its own inboard means of locomotion and navigation. Swapping the location of one's landshare then becomes easy. One's ninho is piloted automatically to one's new landshare location. One's landshare is thus not bound to specific geographical coordinates.

Children born to each binary relationship each have two homes, which each will share with his full and semi-siblings. This is a diverse family environment, which should be conducive to good child development.

In our simple Y-branching network, each node has 3 links whereas each link has only 2 nodes. Consequently, a second option is possible in which each ninho, rather than pertaining to an individual, pertains to a relationship between 2 individuals, as illustrated on the right. With this option, each individual has a half share in 3 homes and each child has a single permanent home. With this second configuration option, each adult is effectively a parent of 3 separate families.

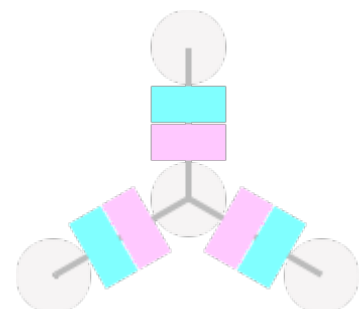

But there is still a problem. The type and depth of friendship needed, to facilitate and sustain a network society, is currently beyond human capability. The necessary faculties exist within us. But in most of us, they are not yet sufficiently evolved to facilitate inter-personal relationships that are strong enough to sustain a large robust social network.

A Necessary Quantum Leap

Being brought up and formally schooled in the ways of this *new social order* is not enough. This alone cannot empower a person to successfully fulfil the role of being one of its vital nodes. To be able to do so requires much more than an intellectual appreciation of how one should proceed. It requires something that is currently beyond our reach. This is why the *free love* Hippy communes of the 1960s were predestined to fail.

Any society must be regulated. But a *natural* human society - that is, human society separate from any imposed political régime - is like any other group of animate life-forms such as a colony of insects or a [herd of animals](#). It does not have an inherent hierarchical control structure. It has no king. It has no elite. The ancients knew this:

"Go to the ant, thou sluggard; consider her ways, and be wise: which having no guide, overseer, or ruler, provideth her meat in the summer, and gathereth her food in the harvest." - Proverbs 6:6-8

Natural human society is not a structured machine. It is a [complex dynamical system](#). Consequently, if it is going to work properly, its means of control cannot be centralised. It must be regulated some other way. Its regulatory mechanism must be distributed. It must be built into each of its individual components.

The structure that best lends itself to distributed control is the *network*. A society, whose individuals are linked together in a network, has no hierarchical tree-structure. There are no superiors and inferiors. All nodes in a network are of equal status. Consequently, a network society cannot be regulated by imprisoning the individual in a cage of law enforced by State violence. A State is, of necessity, hierarchical. So, what form must this *distributed control* take?

It must take the form of a *set of rules* by which the individuals that make up the society interact with each other. Ants and bees have relatively simple sets of such rules etched into their instincts, which they are automatically constrained to follow. Human beings, on the other hand, have free-will in so far as they can consciously choose whether or not they will follow any particular set of rules. So, if a network society is going to work, every individual must adhere to the same set of rules. These rules must become the network society's Constitution.

The Constitution of a network society is therefore nothing more than a Protocol that defines the method by which, and bounds within which, any member of the society may interact with any other. These must be designed so as to ensure that inter-personal dealings are always constructive and benign. This way, they will preserve the stability of the society as a whole, while protecting the well-being and maximizing the fulfilment of each individual. In other words, they must both motivate and constrain each to love his neighbour as himself.

But no Constitution can enforce itself. The rules it comprises, however well founded they may be, cannot make people obey them. Yet, for a network society to function, its rules must be rigorously adhered to by all. Since a network society contains no external agent of enforcement, the only way this can be achieved is for each member of society to enforce society's rules upon himself. Each must be his own policeman.



This new society cannot therefore have natural human selfishness as its driving force. The whole network would fall apart in no time. What is required is a *paradigm-shift* in the [nature of relationships](#). This demands a *quantum leap* in the evolution of the human spirit. [Human consciousness](#) must somehow become enabled and inspired to take control of its desires and contain jealousy and possession within their proper bounds. It must undergo a complete spiritual internalisation of the natural precepts of the [human conscience](#). Its laws must become written in our hearts. This will give each the *inherent desire* to love neighbour as self. Loving neighbour as self will thus become the personal focus, on-going project and life objective of every member of this new society.

In order for this to happen, however, some kind of *active agent* is needed to motivate or energise this necessary *quantum leap* in the evolution of the human spirit. But what? I think it is something closely analogous to what the Judeo-Christian Bible portrays as the Holy Spirit. People imbued with the [Holy Spirit](#) are apparently somehow empowered to understand the law, and reflect the love, of God. However, when I observe the attitudes and behaviours of most religious people, this is not what I generally see, feel or experience.

Notwithstanding, I am encouraged by the fact that I do occasionally come across amazing individuals who definitely seem to have undergone this *quantum leap*. They seem to emerge from all kinds of religious and philosophical persuasions, including atheists. Consequently, I deduce that this *quantum leap* in the evolution of the human spirit must be something that is taking place spontaneously in individual minds here and there throughout humanity. What is certain, however, is that there are, at present, far too few to constitute the critical mass necessary to implement a network society. It will have to wait for a future age.

In The Meantime...

In the light of all this, what can we do now to prepare for the collapse of the present world order of oppressive hierarchies? After all, we are little more than a fragile network of intimate friends who share some radical ideas. We have our knowledge and plans. But we have no power or influence. Most people today are too lazy to think for themselves. They prefer to lap up the spin of biased media. Their entire political and moral belief systems generally emerge from nothing more than the *mêlée* of a Friday night beer haze. They're simply not interested.

All we can do at present is make our alternative knowledge available to whoever shows interest, thereby inducing them to think. But we must not preach. We must never try to ram our ideas down people's throats. That provokes unconditional rejection. Nevertheless, when asked, during the course of a conversation, I give my opinion without compromise. I explain the absurdity and self-contradiction of the *elitist private corporate spin-controlled representative democratic hierarchies* under which we now live. And then, if asked further, I expound what I think would be a better form of society. Of course, I get some funny looks from some people. But that is to be expected.

We must also ensure our survival. We need to build our network and protect it against the State and corporate forces that forever threaten to erode and destroy it. But what will keep us together? Our connectedness is fragile. Initially, the nature of the links in our network will be that of shared values. This kind of intellectual link is strong, but not enough to withstand attack by civil force or distrust induced by some infiltrating agency. We must, as rapidly as possible, upgrade the nature of our network links to that of strong and trusting [friendship](#). This will render our network much more robust. And at the present time, I think this is as far as we can go.

In the future, after some generations have passed, perhaps our network will be able to concentrate on seeking out and attracting those precious few whose minds have undergone that quantum leap in

the evolution of the human spirit. It will, I think, have to be left to them to develop the network into the invincible entity that can only be secured through the intimate bond of [inter-gender friendship](#). I do not think that those of us who have not undergone this quantum leap will be able to control the latent lusts of jealousy and possession sufficiently to implement the [connective force](#) of open and inclusive love. I know that I couldn't. And only this will be strong enough to withstand the destructive forces of lust, envy and selfish gain that prowl the present world.

I think that the proportion of individuals in the population with minds that have undergone the quantum leap is increasing. And it is set to increase at an even faster rate as more and more children become raised within the nurture of the network. I hope that their number reaches the critical mass by the time the present order collapses.

The limitations of life in this present world are indeed hard to bear. One cannot realize one's ultimate dreams here. Nevertheless, I find great satisfaction in knowing what I would do if I were to live in a world where I had the means and the freedom to do it. Perhaps, one day, I will.

[PREV](#) | [NEXT](#) | © Dec 1996, Sep 2008, Sep 2012 Robert John Morton

© This content is free and may be reproduced unmodified in its entirety, including all headers and footers, or as “fair usage” quotations that are attributed as follows: “ - [article name] by Robert John Morton <http://robmorton.20m.com/>”